

MATHEMATICS TEST 1 - ANSWERS

1. 40.32 2. 25000 3. 411 4. 8.09 5. 448 6. $3\frac{2}{5}$ 7. 0
8. $\frac{1}{10}$ 9. \$10 10. 108 11. < 12. $\frac{3000}{6} = 500g$ 13. Wednesday

14. $9 \times 3 = 27 \text{ cm}^3$

15. Parallelogram

16.

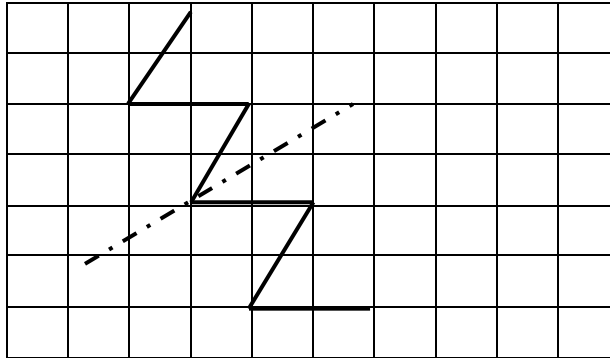

17. C – triangular base prism 18. $58 \times 5 = 290$ 19. 32 20. $4 \times 6 = 24$

21. 25 and 23 22. 8 poles = 7 spaces ($9.5 \times 7 = 66.5m$)

23. $(\frac{240}{6} = 40 \text{ tables}) (40 \times 5 = 200 \text{ chairs}) (200 - 17 = 183) (\frac{183}{3} = 61 \text{ chairs})$

24. Purchasing one of each snack will cost Sita \$23. She will have a balance of \$22. She can buy 2 Nuts and 2 Juice with the change to give a total of 7 snacks and no money remaining.

25. $(\frac{20}{100} \times \frac{165}{1} = \$33) (165 - 33 = \$132)$

26. Using a common factor of 4 to multiply the numerator and denominator of $\frac{2}{3}$ will show that the two fractions are equivalent fractions. Therefore the two fractions are equal.

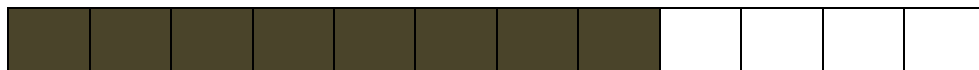

27. $(24 + 9 = 33) (33 \times 7 = 231)$ 28. $(0.25 = \frac{25}{100} = 25\% \text{ or } \frac{1}{4}) (\frac{3}{4} = 75\%)$ Therefore, both answers are correct since both answers will result in one whole.
(Any diagram to show 3 parts and 1 part to make one whole.)

29. $58 - (18 \times 2) = 22$ ($\text{width} = \frac{22}{2} = 11cm$) Area = $18 \times 11 = 198$

30. $(800cm - 465cm = 335cm \text{ or } 3m \ 35cm)$

31. Using reasoning - $\frac{3}{4}$ remained ($\frac{3}{4} \times \frac{2000ml}{1} = 1500ml \text{ or } 1.5l$)

32. $(800 \times 600) \div (40 \times 20) = 600 \text{ tiles} (600 \times 12 = \$7200)$

33.

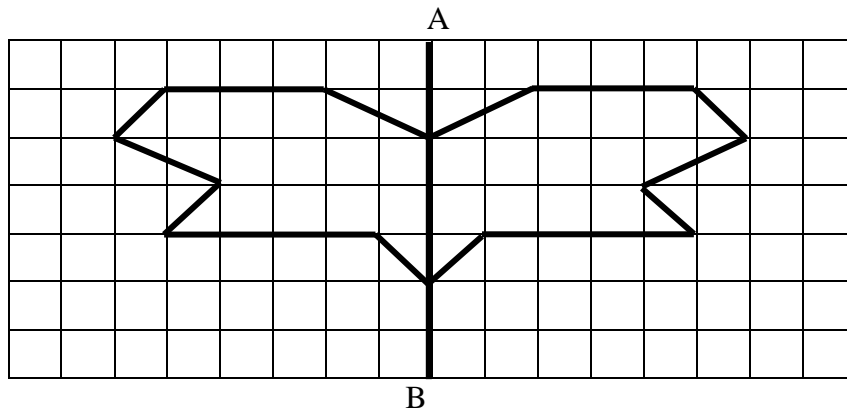

34. 6 right angles

35. $(60 + 35 + 55) \div 3 = 50$ ($50 \times 2 = 100$) ($100 - 84 = 16$)

36. Martin (Martin and Laura) This/These parents are able to convince more people to purchase tickets. They sell tickets at a faster rate than the other parents.

37.a. ($7.5 \times 4 = 30\text{kg}$) ($\frac{30}{5} = 6\text{kg per pack}$) b. ($180 \times 4 = 720$)

($720 + 140 = \$840$) ($\frac{840}{5} = \168)

38. (a) $25 \times 2 = 50$ minutes for one day. ($50 \times 4 = 200$ minutes for 4 days) ($200 + (25\text{mins for Thursday evening}) = 225\text{minutes}$ or 2hours 45minutes or $2\frac{3}{4} \text{ hrs}$)

(b) $1250 \times 9 = 11250\text{m} = 11\text{km } 250\text{m}$ or 11.25km

39. a.

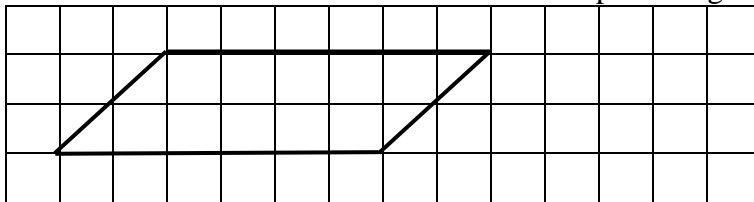

b. parallelogram

40. (Total stamps collected = $30 \times 5 = 150$) (8×1) + (7×4) + (6×3) + (5×8) = $8 + 28 + 18 + 40 = 94$) ($150 - 94 = 56$) ($56 \div 4 = 14$ stamps)

MATHEMATICS TEST TWO – ANSWERS

1. Eight hundred and seven thousand and three. 2. 5.22 3. 1374 4. 4 5. $\frac{15}{4}$
 6. $\frac{1}{4} \times \frac{80}{1} = 20$ 7. $32 \times 5 = 160$ 8. 100 9. 0.08 10. 3 11. 4.83kg
 12. $12 \times 4 = 48\text{cm}^2$ 13. $\frac{1200}{1000} = 1.2 \text{ litres}$ 14. $6\text{cm} - 2\text{cm} = 4\text{cm}$

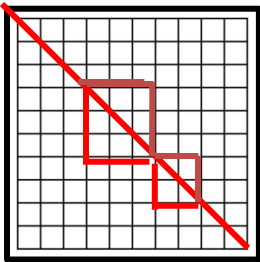

15. 16. Angle C 17. Cube 18. 4 fishes 19. 7

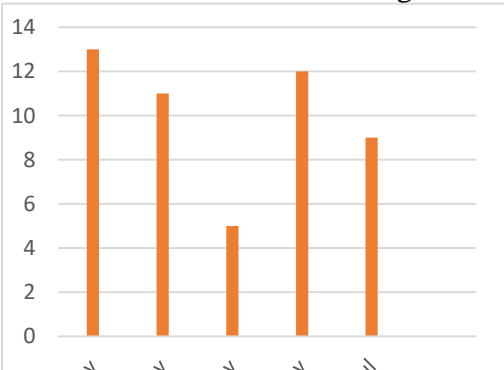

20.
 21. $6\frac{5}{6} + 1\frac{2}{3}$ ($\frac{5}{6} + \frac{2}{3} = \frac{9}{6} = 1\frac{1}{2}$) *Ans* = $8\frac{1}{2}$
 22. $(8 \times 9 = 72)$ ($72 - 4 = 68$) ($68 \div 2 = 34$) ($34 + 4 = 38$ years old)
 23. Ryan will make more money. Ryan will have less in a heap for the same price which means he is selling at a higher price. Ryan will have more heaps to sell and will end up with more money after selling more heaps than David.
 24. $\frac{150}{9} = 16 \text{ R } 6$ ($9 - 6 = 3$ more persons)
 25. ($\frac{1}{3}$ remainder = 20) (Remainder = $20 \times 3 = 60$) ($\frac{4}{5} = 60$) (Total = $\frac{60}{1} \times \frac{5}{4} = 75$ oranges)
 26. $(500 - 350 = 150)$ ($\frac{150}{500} \times \frac{100}{1} = 30\%$)
 27. (1 chair = $\frac{1050}{3} = \$350$) (5 chairs = $350 \times 5 = \$1750$) (A table = $3500 - 1750 = \$1750$)
 28. $\frac{1}{4} \times \frac{450}{1} = \112.50 ($450 - 112.50 = \$337.50$) 29. ($2\frac{1}{4}$ litres = 2250ml) ($\frac{2250}{150} = 15$)
 30. $\frac{200 \times 50}{20 \times 10} = 50$ tiles ($50 \times 7 = \$350$) 31. $15000 - (6474 + 4087) = 4439\text{g}$
 32. C = 50, B 14, A = 85

33. $\frac{3}{4}$ 34. Square-Based Pyramid

35. Akeel – Frequency = 4

Renny	### ### ###	
-------	-------------------	--

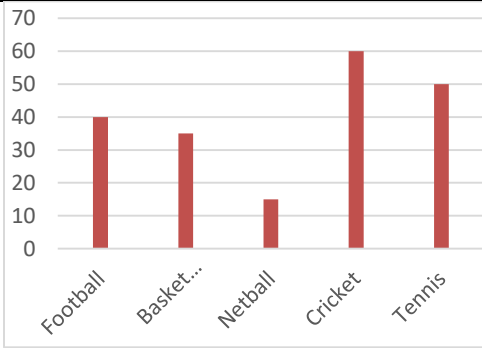

36.

37. $(28 \times 4 = 112)$ $(42 \times 3 = 126)$ $(500 - (112 + 126) = 262)$ $(262 \div 2 = 131 \text{ Two-Seaters})$

38. (Route A = $3260 + 2500 + 1700 = 7460\text{m}$) (Route B = 6750m)

(Route C = $2200 + 2050 + 1035 = 5285\text{m}$)

Kerol should take Route C to get to school. Route C is the shortest of the three routes and by taking Route C, he would get to school faster than the other Routes.

39. (a)

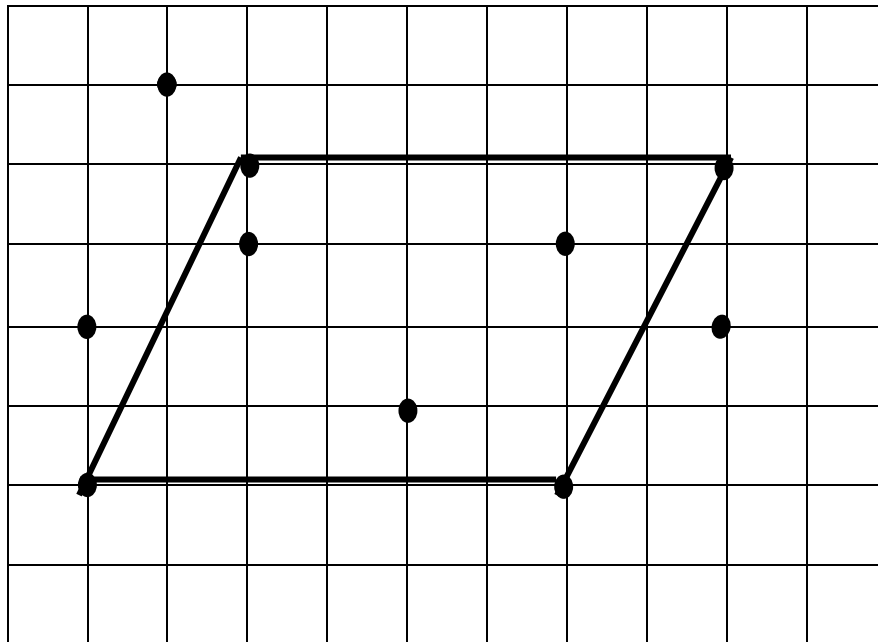

(b) Zero lines of symmetry (c) 2 angles

40. ST. THOMAS PRIMARY SCHOOL has more children living near the school. – More children walk to school which indicates that more children live within walking distance from the school. If children live far from the school, most likely children may not be able to walk to school.

MATHEMATICS TEST THREE – ANSWERS

1. five hundred and seven thousand and ninety-two. 2. 6.5 3. >

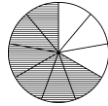

4. $\frac{90}{100} \times \frac{60}{1} = 54$ 5. 6. 5^2 7. $\frac{2}{5} \times \frac{9}{10} = \frac{9}{25}$ 8. $\frac{48}{60} = \frac{4}{5}$
 9. $(3370 - 337 = 3033)$ 10. 25c 11. 14cm 12. $11 \times 11 = 121\text{cm}^2$
 13. $\frac{240}{60} = 4 \text{ hours}$ 14. P of square/rectangle = $15 \times 4 = 60$ ($60 - 10 = 50$)
 $\frac{50}{2} = 25\text{cm}$ 15. Isosceles Triangle

16. cuboid

17. 2 18. $(124 + 286 + 208) \div 3 = \frac{618}{3} = 206$ 19. $\frac{72}{12} = 6 \text{ children}$
 20. $46 - 15 = 31$ at least 21. $(7\frac{1}{2} - 3\frac{7}{10}) (\frac{5}{10} - \frac{7}{10}) (\frac{15}{10} - \frac{7}{10} = \frac{8}{10} = \frac{4}{5}) (6 - 3 = 3) \text{Ans} = 3\frac{4}{5}$
 22. 29.45 23. $(\frac{1}{4} \times \frac{80}{1} = \$20) (\frac{40}{100} \times \frac{80}{1} = \$32) (80 - (32 + 20) = 28) (\frac{1}{2} \times \frac{28}{1} = \$14)$
 24. $\frac{9}{20} \times \frac{100}{1} = 45\%$
 25. Dec = $35 \times 3 = 105$ (Total stamps = $105 + 35 = 140$) ($\frac{105}{140} = \frac{3}{4} = 0.75$)
 26. $(\frac{24}{3} = 8) (5 \times 8 = 40 \text{ cups of water})$
 27. $(47 - 7 = 40) (\frac{2}{5} \times \frac{40}{1} = 16) (16 + 7 = 23 \text{ years now})$
 28. $(1 \times 2) + (2 \times 5) + (1 \times 8) = 20$ points ($80 - 20 = 60$ points) ($60 \div 10 = 6$ times)
 29. $(80 + 80 = 160 = 2 \text{ lengths}) (160 \times 2 = 320 = \text{twice around field}) (500 - 320 = 180 = 4 \text{ width}) 180 \div 4 = 45\text{m for width}$ 30. $4.75 + 6.04 = 10.79\text{km}$
 31. Mark = 64 cubes. Jenny has 10 cubes. Missing cubes = $64 - 10 = 54$ cubes

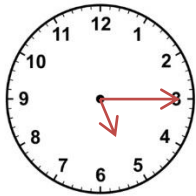

Clock B

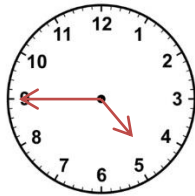

Clock C

32.

33.

SHAPES	PROPERTIES OF SHAPES
Shape B	Has only one pair of perpendicular lines and two right angles.
Shape A	A quadrilateral with no right angles and two pairs of parallel lines.

34.

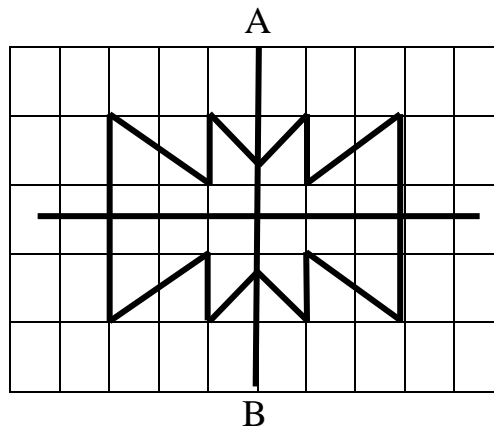

35. $(7 + 8 = 15 \text{ students})$

36. Wednesday – No lunches were being served on Wednesday.

37. (a) $(\frac{150}{3} = 50)$ $(50 \times 4 = 200 \text{ pies})$ (b) $50 \times 30 = \$1500$

38. Distance walked on Tuesday = $948 \times 2 = 1896$, Distance walked on Wednesday = 2844m
Total for three days = $948 + 1896 + 2844 = 5688\text{m}$ (Total time = 72 minutes)

Average distance per minute = $5688 \div 72 = 79\text{m}$

39. (a) 1. A quarter turn in an anticlockwise direction
2. Three-quarter turns in a clockwise direction.
(b)

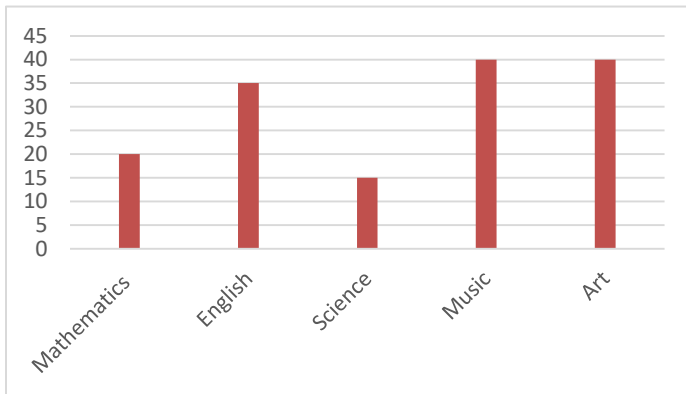
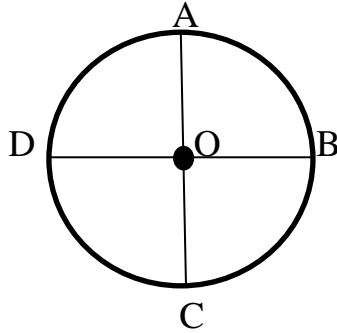

40.

$150 - (40 + 35 + 15 + 20) = 40 \text{ Art}$

$(35 - 20 = 15)$ $(\frac{15}{150} \times \frac{100}{1} = 10\%)$

MATHEMATICS TEST FOUR – ANSWERS

1. 1265

2. Four hundred and sixty-two thousand and seventy

3. $27 \times 6 = 162$

4. 16.2

5. $\frac{12}{8} = 1\frac{1}{2}$

6. $\frac{1}{8}, \frac{1}{6}, \frac{1}{3}, \frac{1}{2}$

7. $40\% \div 2 = 20\%$

8. $\frac{80}{4} = \$20$

9. $\$320 - \$65 = \$255$

10. $\$17.85 - \$14.97 = \$2.88$

11. 450cm

12.

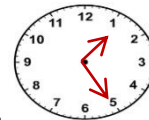

13. $\sqrt{121} = 11$

14. $2\frac{1}{2} \text{ l} = 2500\text{ml}$ $(\frac{2500}{250} = 10 \text{ glasses})$

15.



16. 3 – right angles

17. Scalene triangle 18. ~~///~~ ~~///~~ // 19. Cricket 20. $75 - 60 = 15$ children

21. $(24 \times 4 = 96)$ 22. $\frac{45}{3} = 15$ ($10 \times 15 = 150$ cups)

23. $\frac{2}{5} + \frac{3}{10} = \frac{7}{10}$ ($\frac{10}{10} - \frac{7}{10} = \frac{3}{10}$ left) 24. $(2 + 1 + 3 = 6$ poles make one group)
 $(\frac{40}{6} = 6$ groups R 4) ($6 \times 3 = 18$ green + 1 green from the remaining four = 19 green)

25. $\frac{1}{2} \times \frac{750}{1} = 375$ ($\$750 + \$375 = \$1125$)

26. (a) $\frac{1}{3}$ (b) 35% (c) 0.06 27. 25, 36, 144

28. ($\frac{3}{4}$ of R = 90) ($R = \frac{90}{1} \times \frac{4}{3} = 120$) ($\frac{3}{5}$ of Whole = 120) ($Whole = \frac{120}{1} \times \frac{5}{3} = \200)

29. ($\frac{9750}{250} = 39$ bags) ($39 \times \$3 = \117) 30. $40 + 15 + 35 = 90$ mins. $7:15 - 1:30 = 5:45$ a.m.

31. ($(0.75m = 75cm)$ ($\frac{75}{15} = 5$) ($5 \times 10 = 50$ beads)

32. (Perimeter of Sq. = $9 \times 4 = 36$) ($36 - (12 + 12) = 12 = 2$ -width) (Width = $12 \div 2 = 6$ cm)

33. Triangular-Based Prism – This shape will make it easiest for water/objects to run off the roof/ not settle on the roof.

34. a & c 35. $(23 \times 4 = 92)$ ($92 + 33 = 125$) ($125 \div 5 = 25$)

36. Cats – The most cats were sold. Most people liked cats. The store owner will make more money in his business from selling cats.

37. ($\frac{1}{2} \times \frac{260}{1} = 130$ marbles) ($\frac{60}{100} \times \frac{130}{1} = 78$ marbles) ($\frac{2}{3} \times \frac{78}{1} = 52$ marbles)

38. $(250 \times 10 = 2500g)$ ($2500g - 750g = 1750g = 1.75kg$) Nearest Whole = 2kg

39.

Number of angles less than a right angle	Number of angles greater than a right angle	Number of angles equal to a right angle	Two angles equal to a half turn
3	2	0	(de) (ab)(ad) (cb) (cd) Any one

40. (a) Total = $(76 \times 5 = 380)$ (Spelling = $380 - (65 + 75 + 75 + 95) = 70$)
 (b) $(86 \times 5 = 430)$ ($430 - 380 = 50$ more marks)

MATHEMATICS TEST FIVE – ANSWERS

1. 1 2. $\frac{5}{8} \times \frac{40}{1} = 25 \text{ pages}$ 3. $\frac{45}{100} \times \frac{80}{1} = 36$ 4. 503.42 5. 17

6. $2\frac{1}{2} \times 16 = \frac{5}{2} \times \frac{16}{1} = 40\text{km}$ 7. 92.2 8. 7 9. 5 10. $2014 - 18 = 1996$

11. $(8 + 7) \times 2 = 30\text{cm}$ 12. 3.5 or $3\frac{1}{2}$ 13.  14. $15 \times 15 = 225\text{cm}^2$ 15. B

16. equilateral 17. Cone 18. Dog 19. $305 - (64 + 74 + 67) = 100$ ($\frac{100}{2} = 50$)

20. $305 \div 5 = 61$ 21. $(450 + 35 = 485)$ ($485 \div 25 = 19 \text{ R } 10$) Reasoning – Ans = 20 maxis.

22. $8\frac{7}{10} - 3\frac{1}{5}$ ($\frac{7}{10} - \frac{2}{10} = \frac{5}{10} = \frac{1}{2}$) ($8 - 3 = 5$) Ans = $5\frac{1}{2}$ 23. $(52 \times 12 = 624)$ ($624 + 5 = 629$)

24. $(\frac{1}{4} = \frac{2}{8})$ ($\frac{2}{8} + \frac{1}{8} + \frac{3}{8} = \frac{6}{8} = \frac{3}{4}$ spent) ($\frac{1}{4} = \text{remainder} = \40) ($\text{Total} = \frac{40}{1} \times \frac{4}{1} = \160)

25. $(\frac{2}{5} \times \frac{120}{1} = 48)$ ($\frac{3}{4} \times \frac{48}{1} = 36$ fixed) ($\frac{3}{5} \times \frac{120}{1} = 72$ good) ($\text{Total good} = (72 + 36 = 108)$)

26. $(2\frac{1}{2} + 3\frac{3}{4} + 2\frac{1}{2})$ ($\frac{2}{4} + \frac{3}{4} + \frac{2}{4} = \frac{7}{4} = 1\frac{3}{4}$) ($2 + 3 + 2 = 7$) ($\text{Ans} = 7 + 1\frac{3}{4} = 8\frac{3}{4}$)

27. $\frac{2}{3} = \frac{16}{24} = \frac{4}{6} = \frac{24}{36}$ The answer was found by forming equivalent fractions- by multiplying or dividing the numerator and the denominator by a common number/factor.

28. $(\frac{40}{100} \times \frac{160}{1} = \$64 \text{ per book.})$ ($160 - 64 = \$96 \text{ bag}$) ($96 \times 4 = 384$) ($384 + 64 = \448)

29. $(5\text{kg } 345\text{g} + 2\text{kg } 50\text{g} = 7\text{kg } 395\text{g})$ ($25\text{kg} - 7\text{kg } 395\text{g} = 17\text{kg } 605\text{g}$)

30.

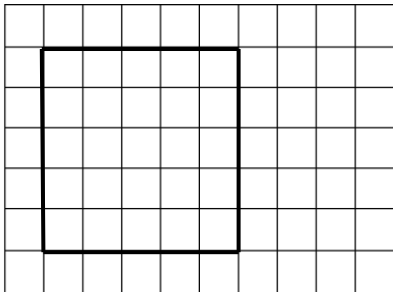

The area of the seventh square can be found by multiplying 7 by 7.

31. $(12.4\text{km} + 2.75\text{km} = 15.15\text{km})$ (Approximately 15km to nearest whole km)

32. $\frac{80 \times 50}{5 \times 5} = 160$

33. E (East)

34. Isosceles Triangle

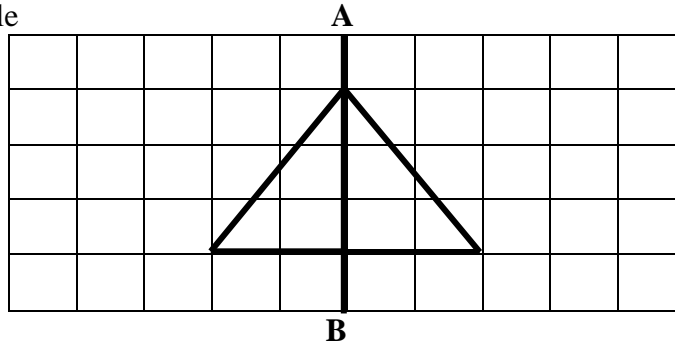

35. (a) $1415 - (257 + 323 + 290 + 265) = 280$ for Wednesday (b) $1415 \div 5 = 283$

36. $120 - 90 = 30$ children

37. ($12 \times 2 = 24\text{kg}$ corn per bed) ($8 \times 6 = 48\text{kg}$ of peas per bed) ($24 + 48 = 72\text{kg}$ total per bed)
($72 \times 40 = 2880\text{kg}$ in the truck)

38. ($15 \times 200 = 3000\text{ml}$) ($5000 - 3000 = 2000\text{ml}$) ($2000\text{ml} \div 250\text{ml} = 8$ glasses)
($15 + 8 = 23$ persons)

39.

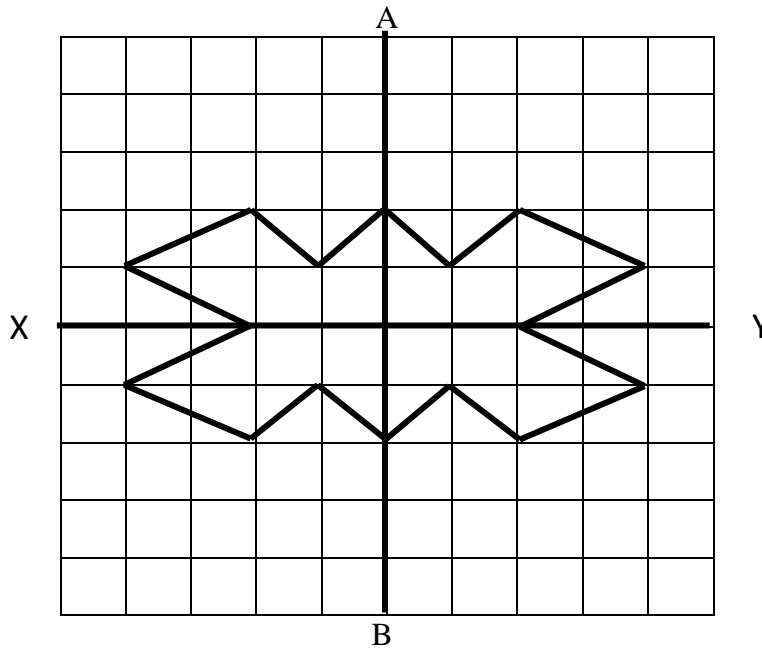

40. Game 1 = 22, Game 2 = 32 Game 3 = 26 Game 4 = 40

Total points = $22 + 32 + 26 + 40 = 120$ Ans: $\frac{3}{8} \times \frac{120}{1} = 45$ points

MATHEMATICS TEST SIX – ANSWERS

1. Four hundred and eight thousand and seven. 2. 3000 or 3-thousands 3. $\frac{5}{100} = \frac{1}{20}$
4. 3 5. $\frac{41}{8}$ 6. 8000 7. 66 8. 8 9. (15 x 7 = 105 buttons)
10. $\frac{300}{5} = 60$ five-dollar bills 11. millilitres 12. $\frac{200}{60} = 3$ hours 20 minutes
13. $(60 - (12 + 12) = 36)$ ($36 \div 2 = 18$ cm) 14. (3kg - 2kg = 1kg) (1kg = 2 halves) Ans = 2
15. Triangular-Based Prism 16. 2 lines 17. Angle B
18. (24 x 2 = 48) (48 - 17 = 31) 19. (6 x 2 = 12 students) 20. (20 - 8 = 12)
21. (600 - 240 = 360) ($\frac{360}{600} \times \frac{100}{1} = 60\%$)
22. ($\frac{45}{5} = 9$) (9 x 2 = 18 days)
23. $\frac{3}{8} = 600$ (Total = $\frac{600}{1} \times \frac{8}{3} = 1600$) ($\frac{40}{100} \times \frac{1600}{1} = 640$) (1600 - 640 = 960 animals)
24. (25 x 23 = 575) (575 - 275 = 300)
25. ($\frac{490}{7} = 70$ shirts) ($\frac{70}{8} = 8$ boxes sealed 6 remainder) Answer = 6 shirts
26. (2 + 3 = 5) (60 ÷ 5 = 12) (12 x 2 = 24 groups) = 24 x 4 = 96 ribbons
27. (a) 720 + 83 = \$803 (b) 850 + 130 = \$980
28. One shirt will cost less. (Two shirts will be 60% of total cost. Therefore, one shirt will be 30% of the total cost which is less than the 40% for the trousers.)
29. $\frac{3000}{200} = 15$ packets
30. A = ml B = km C = kg
Distance around = (33 + 17 + 16 + 16 + 13 + 29 = 124m) Twice = 124 x 2 = 248m
31. 8:05am - 6:15am = 1hour 50mins
32. 28-8=20, (20÷2 = 10m the length of the rectangle) Area of square = 10m x 10 m= 100 square meters

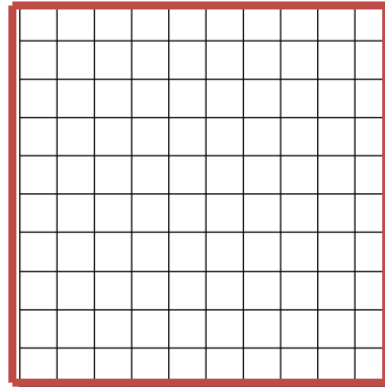
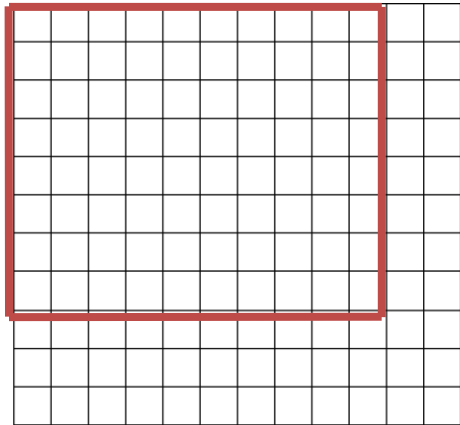

33. 2 lines of symmetry 34. Right-Angle & Isosceles
35. (65 x 5 = 325) (325 - (62 + 73 + 49 + 68) = 73)
36. Shade 7 blocks
37. ($\frac{1}{5} \times \frac{2400}{1} = 480$) (2400 - 480 = \$1920 - Store A) ($\frac{1}{4} \times \frac{2500}{1} = 625$)
(2500 - 625 = \$1875 - Store B) (2400 - 490 = \$1910 - Store C) Store B is cheapest
38. ($\frac{500}{20} \times \frac{400}{20} = 500$ tiles) (500 x \$9 = \$4500) 39. (a) NE (b) SW
40. Birds = (150 - (45 + 38 + 2 + 29) = 36) Snakes are least liked and are most likely to be the least purchased animal by children for pets. Snakes will be kept a longer time at the pet shop since they are the least liked by children and children may not want to take them home.

MATHEMATICS TEST SEVEN - ANSWERS

1. 6125 2. $\frac{1}{10}$ 3. $\frac{1}{4}$ 4. $\frac{2}{5} \times \frac{20}{1} = 8$ blocks. Shade any 8 blocks. 5. 4
 6. 69.36 7. $\frac{7}{14}$ 8. $\frac{12}{16} = 75\%$ 9. \$122.46 10. $\frac{14}{4} = 3\frac{1}{2}$ apples 11. 3090grams
 12. $\frac{9}{3} = 3$ five minutes = 15 mins. (9:30 + 15 = 9:45am) 13. $\frac{150}{5} = 30$ pieces

14. $5200 - 3748 = 1452$ 15.  16. Smaller than a right angle 17. Isosceles

18. $(19 + 7 + 14 + 11 + 14 = 65)$ ($65 \div 5 = 13$) 19. $(25 - 8 = 17)$ 20. $(64 - 32 = 32)$

21. $(54 - 9 = 45)$ ($45 \div 3 = 15$) 22. $(\$60 \times 5 = 300)$ ($\frac{10}{100} \times \frac{300}{1} = \$30.$) ($300 - 30 = \$270.$)

23. $(7 - 3 = 4\text{m for each time})$ (4×4 times = 16m) ($30\text{m} - 16\text{m} = 14\text{m remaining}$)

24. $(6\frac{1}{4} - 3\frac{5}{8} \rightarrow$ Subtract fraction part ($\frac{2}{8} - \frac{5}{8}$) Take one whole from 6 ($\frac{10}{8} - \frac{5}{8} = \frac{5}{8}$)

(Take Whole Numbers - $(5 - 3 = 2)$ Answer = $(2\frac{5}{8})$)

25. $(3.95 \times 2 = \$7.90)$ ($7.90 + 5.50 = \$13.40)$ ($\$20.00 - 13.40 = \6.60)

26. $(12.45 - 4.95 = \$7.50$ for 3 pens)

$(7.50 \div 3 = \$2.50$ per pen) ($2\text{pens} = 2.50 \times 2 = 5.00$) (3 books = $4.95 \times 3 = \$14.85$)

$(14.85 + 5.00 = \$19.85)$

27. (Mon - Fri = $30 \times 8 \times 5 = \$1200$) ($1\frac{1}{2} \times 30 = \$45.$) ($45 \times 4 = \$180$)

($1200 + 180 = \$1380$)

28. $(124 - 64 = 60)$ ($60 \div 3 = 20$) ($20 \times 2 = 40$)

29. $(300\text{cm} - 24\text{cm} = 276)$ $276 \div 12\text{cm} = 23$ weeks

30. $8000 - (1450 \times 2) = 5100.$ ($5100 \div 3 = 1700$) ($1700 + 1450 = 3150$ g or 3kg 150 g)

31. $(84 \div 4 = 21\text{cm})$

32. $(5.75 \times 5 = 28.75)$ ($28750\text{g} \div 50 = 575\text{g}$)

33. (a) Equilateral (b) Scalene 34. (a) Parallel Lines (b) Perpendicular lines

35. $(24 \times 3 = 72)$ ($72 \div 4 = 18$ oranges)

36. Keith should not be selected for the team. He scored the lowest number of runs. He may cause the team's average runs in a game to be low.

37. $(300 \times \$2 = \$600)$ ($45\% = \frac{9}{20}$) ($\frac{9}{20} + \frac{3}{10} = \frac{15}{20} = \frac{3}{4}$) ($\frac{3}{4} \times \frac{300}{1} = 225$)

$(225 \times 2.50 = \$562.50)$ (**LOSS** = $600 - 562.5 = \$37.50$)

38. Length of rectangle = $3 \times 3 = 9$ Width of rectangle = $2 \times 3 = 6$. Area of rectangle = $9 \times 6 = 54$

Total area of rectangles = $54 \times 2 = 108$. Area of square = $3 \times 3 = 9$. Total area of squares = $9 \times 3 = 27$, Total area of shape = $108 + 27 = 135 \text{ cm}^2$

39.

NAME OF SHAPE	PROPERTIES
Parallelogram	Two pairs of parallel lines, no right angles
Square	Four equal sides, four right angles
Trapezium	one pair of parallel lines, no right angles
Rhombus	Four equal sides, no right angles

40. $102 + 85 + 87 + 114 + 72 = 460$) ($\frac{460}{5} = 92$) ($102 + 85 + 87 + 114 = 388$) ($\frac{388}{4} = 97$)
 ($97 - 92 = 5$)

TEST EIGHT – ANSWERS

1. 4 2. 48 3. $7^2 + 1 = 50$ ($5^2 = 25$) ($25 \times 2 = 50$) ($\square = 2$)

4. $\frac{2}{3}$ 5. ($9.00 - 2.73 = 6.27$) 6. 375 7. 3.1 1.3 0.31 0.13

8. $16 \times 9 = 144$ 9. 132 10. $\frac{12}{8} = 1\frac{4}{8} = 1\frac{1}{2}$ cakes

11.



12. ($2000\text{g} - 1350\text{g} = 650\text{g}$) 13. $6:50 - 6:15 = 35\text{minutes}$ 14. $\frac{3000}{400} = 7\frac{1}{2}$

15. Pyramid 16.  17. 5- quarter turns

18. $(18 + 87 + 61 + 75 + 64 + 85) \div 6 = \frac{390}{6} = 65$ 19. P.Cars

20. ($19 - 13 = 6$ more pencils) 21. $\frac{1}{2} + \frac{3}{4} = \frac{5}{4}$ ($\frac{5}{4} \div 2 = \frac{5}{4} \times \frac{1}{2} = \frac{5}{8}$)

22. ($215 - 56 = 159$) ($159 + 215 = 374$ marbles)

23. ($6.30 \div 7 = \$0.90 =$ one pen) ($1\frac{1}{2}$ dozen = $18 \times 0.9 = \$16.20$)

24. ($468 - (25 + 11) = 432$) ($\frac{432}{3} = 144$ female students) ($144 + 25 = 169$ female)

25. ($52 - 18 = 34$) Ans: Any number combination to make 34 except $34 + 0$.
eg: $20 + 14$

26. $\frac{30}{100} \times \frac{450}{1} = \135 ($450 - 135 = \$315$)

27. ($25 \times 5 = \$125$) ($375 - 125 = \250 balance) ($250 \div 25 = 10$ weeks)

28. David's answer is smaller. – David has to share the number into more parts which will make each part smaller.

29. ($3\text{cm} \times 3\text{cm} = 9\text{cm}^2$) (11 squares inside shape) ($11 \times 9 = 99\text{cm}^2$)

30. ($8:00\text{am to } 1:35\text{pm} = 5\text{hrs } 35\text{mins}$) (6hours for parking) ($6 \times 6 = \36) (36×5)

31. ($25 \times 80 = 2000$ cm) ($2000 \div 100 = 20$ m)

32. ($620\text{cm} - 20 = 600\text{cm}$) ($25 + 15 = 40$) ($600 \div 40 = 15$ bags each)
(Total = $15 \times 2 = 30$ bags)

33. Any quadrilateral (four sided figure)

34.



35. $4 + 7 + 5 = 16$ children

36. $(52 - 28 = 24)$ $(24 \div 3 = 8 \text{ Blue})$ $(8 \times 2 = 16\text{-Yellow})$

Blue = 😊 😊 Yellow = 😊 😊 😊 😊

37. $(35 \times 5 = \$175)$ $(2011 - 175 = \$1836)$ $(1836 \div 9 = 204)$ $(204 \times 2 = 408 \text{ CD's})$
 $(408 + 35 = 443 \text{ CD's})$

38. $(10000 \div 250 = 40)$ $(40 \div 12 = 3 \text{ remainder } 4)$. (8 bottles needed to fill the case) $(250 \times 8 = 2000 \text{ mls})$

39.

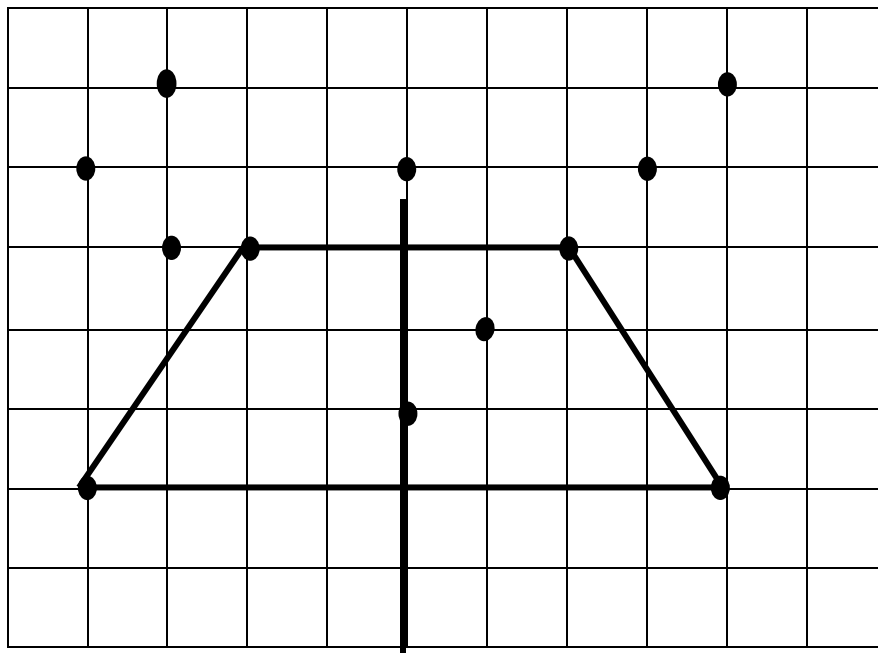

Line of symmetry

40. (a) 125 cubic metres of gravel.

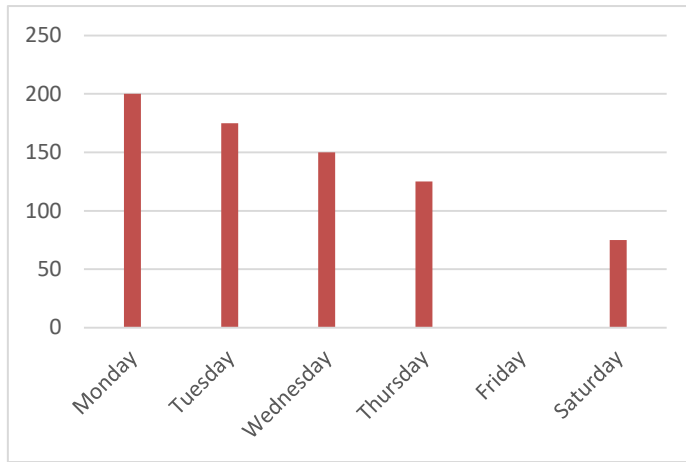

(b)

MATHEMATICS TEST NINE ANSWERS

1. $\frac{4}{10}$ or 4 tenths 2. 300 076 3. $\frac{14}{3}$ 4. $\frac{32}{100} = \frac{8}{25}$ 5. $\frac{18}{30} \times \frac{100}{1} = 60\%$
 6. $8^2 - 35 = 64 - 35 = 29$ 7. $\$8.95 + \$2.30 = \$11.25$ 8. $\frac{20}{100} \times \frac{245}{1} = \49 9. $\frac{2}{8} = \frac{1}{4}$

10. Ben kept $40\% = \frac{40}{100} \times \frac{20}{1} = 8$ marbles 11.

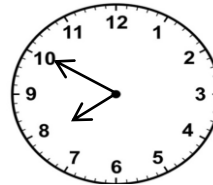

12. kilometre (km) 13. $\frac{450}{10} = 45$ pieces

14. $\frac{56}{4} = 14$ cm 15. Cone 16.  17. < 18. 63 toys

19. Guppy 20. $(45 - 15 = 30)$ children

21. $(\frac{2}{5} + \frac{3}{10} = \frac{4}{10} + \frac{3}{10} = \frac{7}{10})$ $(\frac{10}{10} - \frac{7}{10} = \frac{3}{10})$ saved

22. $(3875 - 287 = 3588)$ ducks $(3875 + 3588 = 7463)$

23. $(17 + 34 = 51)$ m between poles $(18$ poles equal 17 spaces $= 17 \times 51 = 867$ m of cable)

24.

198

 \times

3

 The 23 was distributed into 20 and 3. 198 - 23 times can be 198 - 20 times added to 198 - 3 times

25. $\frac{1}{8} \times \frac{720}{1} = \90 per week $(90 \div 6 = \$15)$ each day. 26. $\frac{612}{1} \times \frac{5}{2} = 1530$ members

27. VENDOR B - Find the cost of one item for each vendor by dividing the number of oranges by cost of the heap. 28. $\frac{80}{100} \times \frac{400}{1} = 320$ $(320 \times 40 = \$12\ 800)$

29.

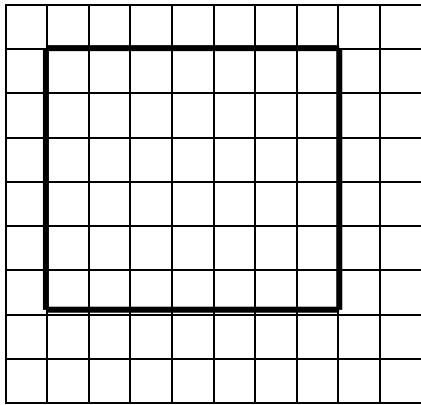

30. 100 blocks needed for cuboid.

$$(100 - 48 = 52)$$

Shape B = 27

$$\text{Missing blocks} = 52 - 27 = 25$$

31. Writing = 65mins Math = 45mins – Difference (65 – 45 = 20mins)

32. 8:15 to 1:30 = 5hrs 15mins. (6hrs per day x \$5 = \$30 per day) (30 x 5 days = \$150)

33.

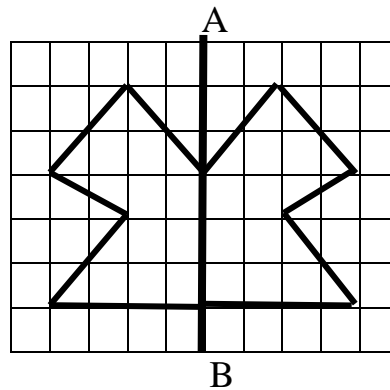

34.

ANGLE	LETTERS
Greater than a right angle	A, B, D
Less than a right angle	C, E

35. $240 \div 20 = 12$ 36. $(75 \times 5 = 375)$ $(375 + 87 = 462)$ $(462 \div 6 = 77)$

37. $20\% = \frac{1}{5}$ sold. $(\frac{4}{5}$ remainder) $(\frac{1}{4} \times \frac{4}{5} = \frac{1}{5})$ $(\frac{3}{5}$ remainder) $(\frac{3}{5} = 60)$ $(\frac{60}{1} \times \frac{5}{3} =$

100 oranges in total)

38. (Route A = $2500 + 2500 + 3045 = 8045\text{m}$) (Route B = $(3070 + 1750 + 3250 = 8070\text{m})$)

Route B is longer. $(8070 - 8045 = 25\text{m})$

39. (a) Container A (b) The cuboid shape will make it easier to stack **more** containers on each other without toppling over. It will be easier to secure the containers when strapped to the truck.

40. (a) Sports Day (b) Most children will come out to support a sports day (parents and past pupils may also come to increase the number of people present.) (The school can sell more items to more people on the sports day)

MATHEMATICS TEST TEN - ANSWERS

1. Seven hundred and five thousand and fifty-six. 2. 0.05 3. 7728

4. 50 000 5. $15 \times 30 = 450$ 6. 14, 1.4, 0.41 0.14 7. $5\frac{2}{3}$

8. $150 \times 12 = 1800$ 9. 9 10.
$$25 \overline{) 2825}$$

11. $2.36 \times 1000 = 2360$ metres 12. 6cm 13. $\$60.00 - \$53.75 = \$6.25$

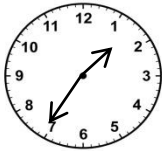

14.

15. cylinder

16. 4 lines

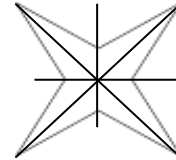

17. D

18. 23

19. ~~HHH~~ ~~HHH~~ 1

20. $21 - 9 = 12$

21. $4\frac{7}{8} + 3\frac{1}{2}$ (Add fraction part $(\frac{7}{8} + \frac{1}{2} = \frac{11}{8} = 1\frac{3}{8})$ (Add whole = $(8\frac{3}{8})$)

22. $(532 - 86 = 446)$ $(446 + 532 = 978)$

23. $\frac{8}{32} = \frac{1}{4} = 0.25$

24. $(60 - 12 = \$48)$ $(48 \div 2 = \$24)$ $(\frac{24}{60} \times \frac{100}{1} = 40\%)$

25. $(16 \times 32 = 512)$ $(512 - 352 = 160)$ $(160 \div 16 = 10$ shelves)

26. 1 pencil = $\frac{15}{12} = \$1.25$ (7 pencils = $1.25 \times 7 = \$8.75$)

27. $(\frac{25}{100} \times \frac{240}{1} = \$60)$ $(240 + 60 = 300)$ $(300 + 240 = \$540)$

28. By rounding each number given to the nearest 1000, it can be determined that Bill worked for approximately \$7000 while Jane worked for approximately \$6000. Therefore, Bill worked for more money.



29. $1 \text{ kg} = 2$ oranges

1 orange = $\frac{1}{2}$ kg or 500g

30. A small square = $3\text{cm} \times 3\text{cm} = 9\text{cm}^2$

12 squares = $12 \times 9 = 108\text{cm}^2$

31. $(\frac{3}{4} \times 20 = 15)$ $(\frac{2}{3} \times 15 = 10\text{cm})$

32. 3 adults = $250 \times 3 = \$750$ per night

1 night for the family = $\$750 + \$250 = \$1000$

2 children = $125 \times 2 = \$250$ per night

2 nights for the family = $1000 \times 2 = \$2000$

33.

SOLID	NUMBER OF FACES	NUMBER OF EDGES	NUMBER OF VERTICES
Cube	6	12	8
Triangular-based prism	5	9	6

34. Triangle B – All the sides are equal.

35. $(16 + 13 = 29)$ $63 - 29 = 34$ $(34 \div 2 = 17)$ Tally = ~~||||~~ ~~||||~~ ~~||||~~ 11

36. Robots – most people like robots – robots are selling fastest among the toys.

37. $(8623 - 6428 = 2195)$ $(8264 - 6843 = 1421)$ $(1421 + 2195 = 3616)$

38. $((1 \text{ litre} = 1000\text{ml}) (\frac{2}{5} \times \frac{1000}{1} = 400)) (5\text{ml} \times 4 = 20\text{ml per day}) (\frac{400}{20} = 20 \text{ days})$

39.

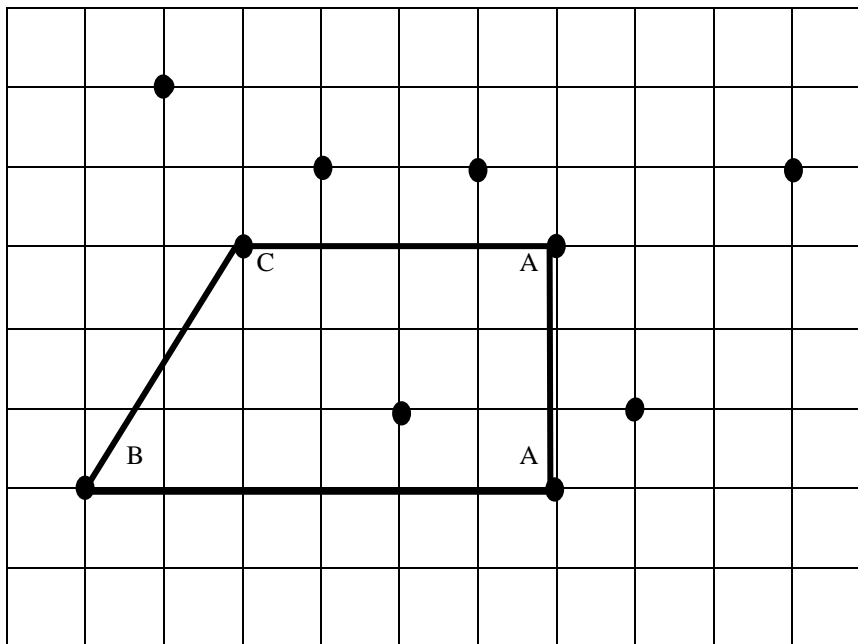

40. The most money should be spent on shirt size 17. Most people in the club are wearing size 17. The most needed shirt size will be size 17.

MATHEMATICS TEST ELEVEN – ANSWERS

- 1.** 425 016 **2.** 42 **3.** 102 **4.** $\frac{8}{12} = \frac{2}{3} = 66\frac{2}{3}\%$ **5.** 1.1 **6.** 9000
7. 25678 **8.** $\frac{4}{10} = \frac{2}{5}$ **9.** $5\frac{7}{9}$ **10.** $128 \times 6 = 768$ pages **11.** cm **12.** 27cm^3
13. 30mins **14.** $80 \times 6 = 480\text{g}$ **15.** AB **16.** Square-Based Pyramid **17.** 5
18. $3 \times 8 = 24$ **19.** 108cm

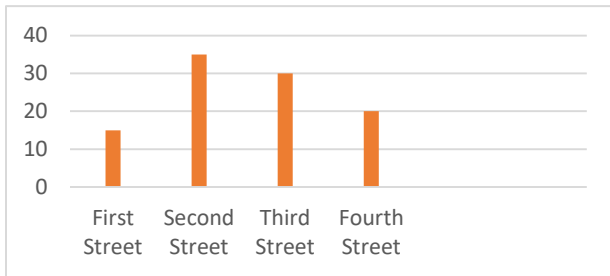

- 20.**
21.

Common Fraction	Decimal Fraction	Percentage
$\frac{11}{50}$		(a) 22%
	(b) 0.75	75%
(c) $\frac{9}{25}$	0.36	

- 22.** $25 \times 13 = 325$ boxes **23.** $\frac{2}{3}, \frac{11}{12}, \frac{5}{12}$
24. $1635 \times 5 = 8175$ bricks needed ($8175 \div 200 = 40 \text{ R } 175$)
 Ans: The builder has to buy 41 pallets. He will not be able to get an exact number of bricks, therefore he has to buy a full pallet and have some bricks remaining instead of buying one less pallet and not be able to complete one of the houses.
25. $\frac{24}{40} \times \frac{100}{1} = 60\%$ **26.** $\frac{1}{2} \times \frac{60}{1} = \30 ($\$30 = \frac{2}{5}$) ($Zack's \text{ Total} = \frac{30}{1} \times \frac{5}{2} = \75)
27. ($35 + 35 + 158 = \$228$) ($500 - 228 = \272) ($272 \div 25 = 10$ hats)
28. 324 114 **29.** ($250 \times 24 = 6000\text{ml}$) ($6000 \div 1000 = 6$ litres) **30.** $\frac{90}{3} = 30$ ($30 \times 5 = 150\text{mins}$)
31. ($1500 \div 250 = 6$) 6th container = Container F - Cost = $6 \times 8 = \$48$
32. Route A = ($1500 + 400 + 500 = 2400\text{m}$) Route B = ($900 + 300 + 650 = 1850\text{m}$)
 Ans: Hazel should take Route B – Route B is shorter. She would get to and from the shop faster than if she uses Route A. (Using Route B will save her time)

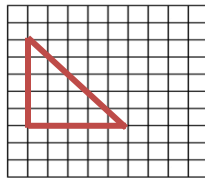

- 33.** East **34.**

- 35.** Total = ($85 + 72 + 75 + 43 + 65 = 340$) Mean = $340 \div 5 = 81 = \text{Grade A}$

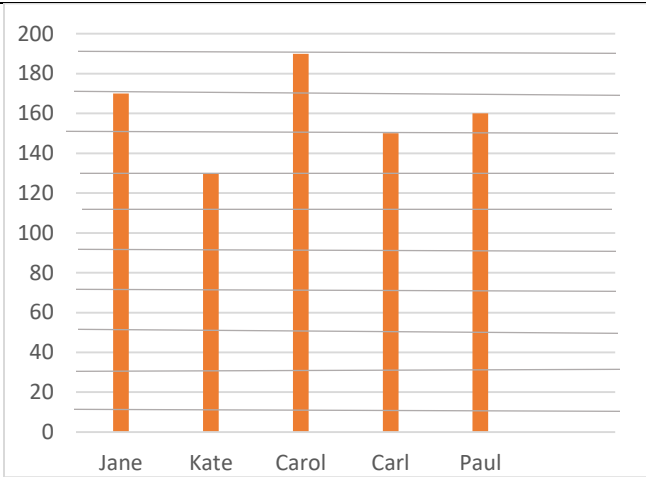

36.

37. $(10 \times 8 = \$80 \text{ per weekday})$ (Mon. Wed. Thurs = 13days $\times 80 = \$1040$)(Sat.= $15 \times 8 = \$120$)
 $(120 \times 5 = 600)$ Total = $1040 + 600 = \$1640$

38. A of Garden = $700 \times 700 = 490000\text{cm}^2$ (A of entire space = $1100 \times 1100 = 1210000\text{cm}^2$)
 (A of walk path = $1210000 - 490000 = 720000\text{cm}^2$) (Tiles needed = $\frac{720000}{24 \times 24} = 1250 \text{ tiles}$)
 $(1250 \times 10 = \$12500)$

39.

Plane Shapes	Number of sides	Number of equal sides	Number of parallel lines	Number of right angles
Parallelogram	4	2 pairs	2 pairs	0
Equilateral Triangle	3	3	0	0
Trapezium	4	0	One pair	0
Square	4	4	2 pairs	4

40. (a) Mathematics (55%) (b) $(55 + 71 + 44 + 60 + 70 = 300)$ $(\frac{300}{450} \times \frac{100}{1} = 66\frac{2}{3}\%)$

TEST TWELVE - ANSWERS

1. 50 407 2. $\frac{19}{5}$ 3. $\frac{30}{1} \times \frac{5}{1} = 150$ 4. 4.4 5. $\frac{20}{100} \times \frac{180}{1} = 36$
6. 9.00 7. $45 \div 100 = 0.45$ 8. $\frac{9405}{6} = 1567 \text{ Remainder} = 3$ 9. $49 - 6 = 43$
- 3.27
5.73
10. $316 + 127 = 443$ 11. 1:50 12. Watermelon

13. $\frac{6000}{500} = 12$ 14. $3000 + 55 = 3055\text{m}$ 15. Isosceles Triangle

16. Square based pyramid 17. B 18. $(56 + 23 + 29 = 108) \frac{108}{3} = 36$

19. $(18 + 12 + 38 = 68)$ $(100 - 68 = 32)$ 20. $(15 - 8 = 7)$ 21. 40% 0.5 $\frac{3}{5}$ $\frac{7}{10}$

22. $(60 - 16 = 44)$ $(44 \div 2 = 21)$ $(21 - 16 = 5)$ 23. $(51 - 15 = 36)$ $(36 \div 3 = 12)$ $N=12$

24. 2-Yellow, 2-Red and 3-Blue 25. $(12\frac{1}{2}\% = \frac{1}{8})$ $(\frac{1}{8} \times \frac{320}{1} = \$40)$ $(320 - 40 = \$280)$

26. $(\frac{1}{4} + \frac{5}{12} = \frac{8}{12} = \frac{2}{3})$ $(\frac{3}{3} - \frac{2}{3} = \frac{1}{3})$ $(\frac{1}{3} \times \frac{600}{1} = \$200)$

27. $(3\frac{1}{2} \times \frac{3}{1} = \frac{7}{2} \times \frac{3}{1} = \frac{21}{2} = 10\frac{1}{2} \text{ km on Tuesday})$ $(10\frac{1}{2} + 3\frac{1}{2} = 14\text{km})$

28. $(148 \times 15 = 2220)$

29. He/She can first find the entire area of the backyard by multiplying 12m by 8m then find the area of the pool by multiplying 8m by 4m. The area of the walk path can be found by subtracting the area of the pool from the area of the backyard.

30. 31. $9:15\text{am} - 7:45\text{am} = 1\text{hr } 30\text{mins.}$ $(8:30 - 1:30 = 7:00\text{am})$

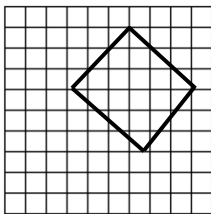

34. Volume = $128 - 64 = 64$ cubes

33.

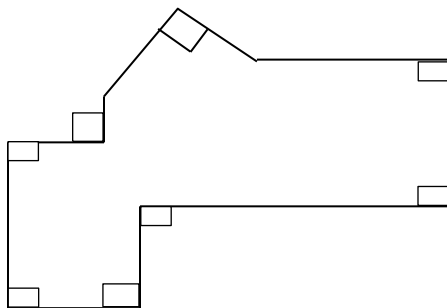

34.

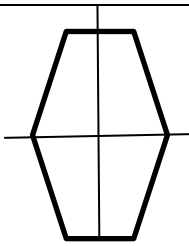

35.

Second Year	
-------------	---

Second Year received the most toys. This class may have more students than the other classes.

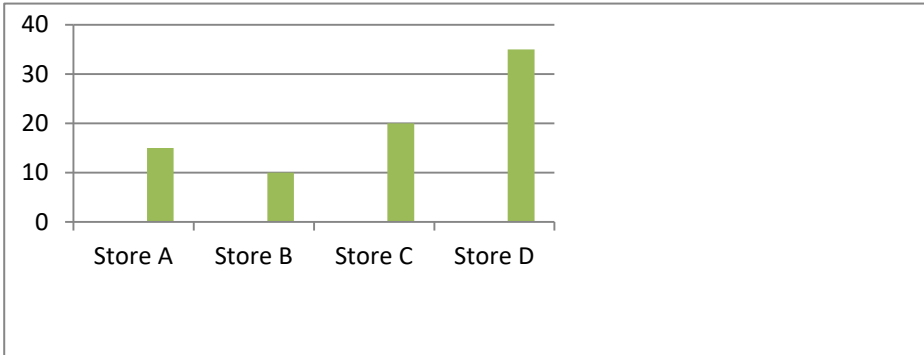

36.

37. $(9836 + 3689 = 13525) \left(\frac{13525}{5} = 2705 \right)$

38. $\left(\frac{1}{3} \times 60 = 20m \text{ as remainder} \right) (20m - 3m35cm = 16m 56cm) (1665 \div 5 = 3m33cm)$
 $(3m33cm \times 3 = 9m 99cm)$

39. (a)



(b) The pattern is formed by using the solid shape then the flat shapes used to form the solid.

40.

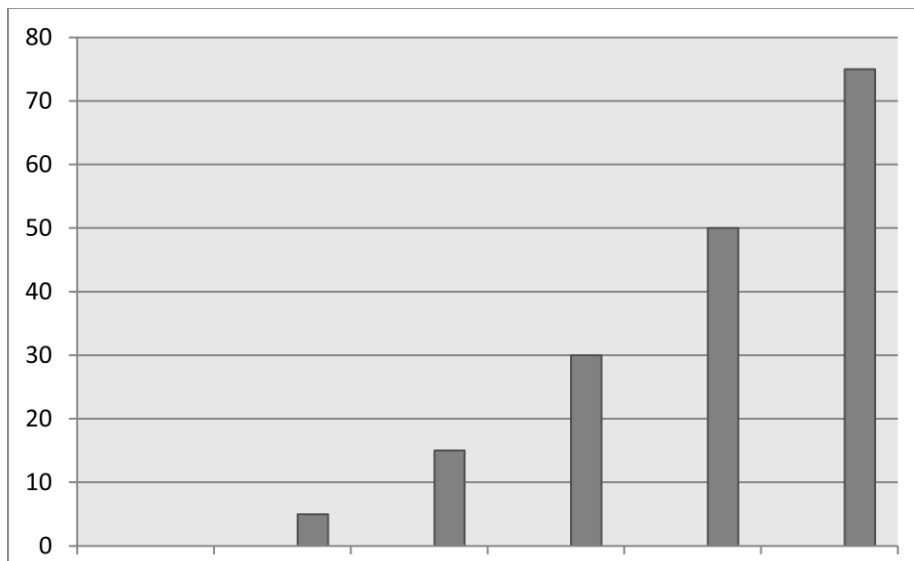

Each day Patsy's **increase in her savings** increased using multiples of '5' starting on Tuesday with 5 and not skipping any multiple. (5, 10, 15, 20, 25)

MATHEMATICS TEST THIRTEEN - ANSWERS

1. 7592 2. 204 3. 340.26 4. 36 5. $\frac{5}{8}$ 6. $7\frac{5}{6}$
 7. $\frac{7}{8} \times \frac{480}{1} = 420$ tickets 8. $(84 - 24) \div 5 = 12$ 9. 7 coins 10. VENDOR A
 11. CONTAINER A 12. $\sqrt{144} = 12$ cm 13. $35 \times 4 = 140$ cm 14. $\frac{270}{60} = 4\frac{1}{2}$ hours
 15. cuboid 16. 0 17. One Whole turn 18. 0
 19. 28

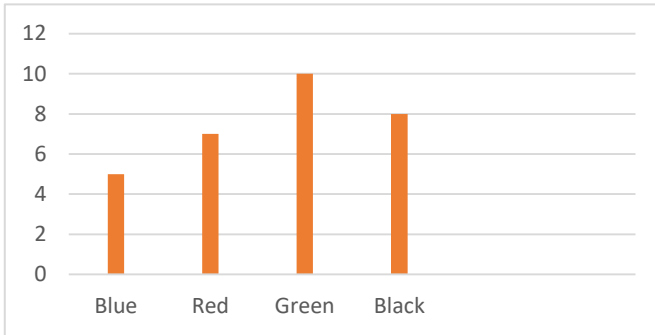

20.
 21. Whole = $\frac{80}{1} \times \frac{5}{2} = 200$ ($\frac{3}{4} \times \frac{200}{1} = 150$)
 22. $\frac{9}{12}$ and $\frac{18}{24}$
 23. Jill applied the distributive law. She knows that 68×55 means the same as $(68 \times 45) + (68 \times 10)$. Therefore, the difference in the answer is 68 ten times.
 24. $(20 \times 16) + 12 = 332$ sweets. ($\frac{332}{12} = 27$ R 8) Remainder would be 8 sweets
 25. $\frac{1}{4} \times \frac{340}{1} = \85 ($340 - 85 = \$255$)
 26. $\frac{45}{3} = 15$ games won (11 games drawn)(Loss = $30 - (15 + 11) = 4$ games)
 27. $(2 + 4 + 8 + 1 = 15)$ ($75 \div 15 = 5$ of each card)
 28. ($\frac{3}{8} \times \frac{160}{1} = 60$)($0.25 \times 160 = 40$)(Apples = $160 - (60 + 40) = 60$ apples)
 29. $(21 \div 2 = 10.5)$ ($10.5 \times 10 = 105$ mm)
 30. $(20 \times 12 = 240\text{m}^2)$ = Area of walk path and swimming pool ($16 \times 8 = 128\text{m}^2$) = A of pool
 ($240 - 128 = 112\text{m}^2$)
 31. Spirit 32. $(1000 \div 4 = 250)$ ($250 \div 10 = 25$)

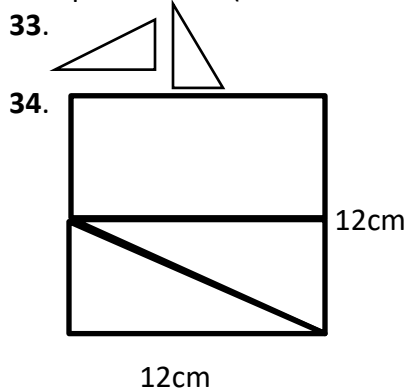

35. ~~###~~ ~~###~~ / - Darren ate the least.
36. Tommy – Tommy has the lowest score. By removing the lowest score, the total will remain higher which will result in a higher mean when dividing the total by the number of children.
Mean of four boys = $(84 + 75 + 90 + 71) \div 4 = 320 \div 4 = 80$
37. $(12 \text{ spaces} - \frac{96}{12} = 8 \text{ pipes between two posts})$
 $(8 \times 6\text{m} = 48\text{m} - \text{distance bet. two posts.})$ (1st and 5th post = 4 spaces)
 $(48 \times 4 = 192\text{m})$
38. $\frac{(900 \times 900)}{30 \times 15} = 1800 \text{ tiles}$ ($1800 \times \$12 = \21600 for tiles) ($21600 + 1250 = \$22850$)
- 39.

Plane Shape/Solid	Properties
<u>Square</u>	4 right angles, 4 equal sides
<u>Cuboid</u>	12 edges, six faces that are not all equal, eight vertices
<u>Parallelogram</u>	Two pairs of parallel lines, no right angles, opposite sides equal in length. All sides are not equal.
<u>Isosceles Triangle</u>	Three sides, two of which are equal.

40. (a) $\frac{240}{3} = 80$ (b) $85 \times 3 = 255$ ($255 - 240 = 15$ more marks)

MATHEMATICS TEST FOURTEEN– ANSWERS

1. 6000 2. 49 3. 1008 4. 135 5. $\frac{11}{3}$ 6. $4\frac{2}{5}$ 7. first row 8
 second row 2
8. 23 9. \$121.70 10. 6.2 11. 64 cm^2 12. 6.5cm 13. June 21

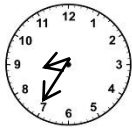
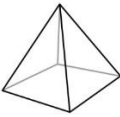
14.  15.  16. G 17. L 18. 91 19. Angel 20. 4

21. $(350 - 140 = 210)$ $(\frac{210}{350} \times \frac{100}{1} = 60\%)$ 22. $(397 \div 24 = 16 \text{ R } 13 \text{ Reasoning} - 17^{\text{th}} \text{ case})$

23. $(\text{Keva} = \frac{45}{1} \times \frac{8}{3} = 120)$ Total = $(120 + 45 = 165)$

24. Kevin's drawing is correct. He made equivalent fractions of twentieths. $\frac{3}{10}$ was changed into $\frac{6}{20}$ and $\frac{2}{5}$ was changed into $\frac{8}{20}$.

25.

Item	Quantity	Total Cost
Bag	$190 \div 95 = 2$	$243 - (45+8) = 190$
Glue	$45 \div 15 = 3$	\$45.00
Ruler	2	\$8.00
Total		\$243.00

26. Tom can make equivalent fractions and change $\frac{2}{3}$ to $\frac{6}{9}$ then compare the 6 ninths with the 5 ninths and see that 2 thirds is the larger fraction.

Diagram -

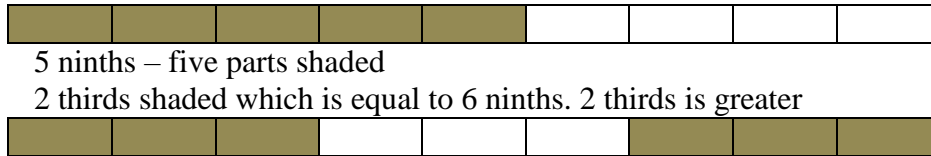

27. Year 1 = 14 Year 2 = 18 (total = $14 + 18 + 23 + 29 + 36 + 44 = 164$)

28. ($15 \times \$4 = \60) ($15 \text{ plums} \div 3 = 5 \text{ groups}$) ($\$15 \times 5 = \75) (Profit = $75 - 60 = \$15$)

29. ($15\text{cm} = 150\text{mm}$) ($150\text{mm} - 14\text{mm} = 136\text{mm}$) 30. (Each square = 4cm^2) ($16 \times 4 = 64\text{cm}^2$)

31. (a) Clock B (b) 50 minutes

32. (64 needed to fill the box) (Have 10 in box) (Missing $64 - 10 = 54$)

33.

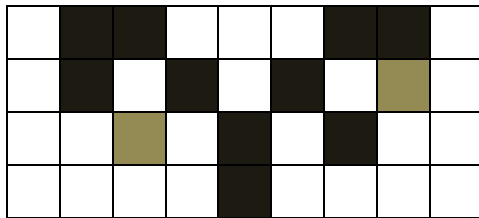

34.

TURN	BETTY	CANDICE
START	North	North
1	South	<u>West</u>
2	North	South
3	South	<u>East</u>
4	North	North

35. $(55 + 40 + 37 + 62 + 71) \div 5 = 53$ ($53 + 9 = 62$) = Jerry

36. Store B – This store has the highest sales. It is able to attract more people to buy toys and will have a greater chance of selling more of Mr. Mike’s toy cars.

37. $(12 \times 2 = \$24)$ $(144 - 24 = \$120)$ $(120 \div (6+2) = 15 \text{ pencils/15 sharpeners})$

Total pencils = $15 + 12 = 27$ pencils

38. $(25\text{cm} \times 4 = 100\text{cm} = 1\text{m for four post})$ $(16\text{m} - 1\text{m} = 15\text{m for three spaces})$

$(\frac{15}{3} = 5\text{m} = 1 \text{ space})$ $(2^{\text{nd}} \text{ to } 10^{\text{th}} \text{ post means } 9 \text{ post} = 25\text{cm} \times 9 = 225\text{cm} = 2.25\text{m}) + (8 \text{ spaces}$

$8 \times 5 = 40\text{m}) = 2.25\text{m} + 40\text{m} = 42.25\text{m}$

39. (a) Triangles needed = 8

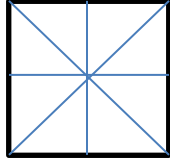

(b) Area = $18\text{cm} \times 18\text{cm} = 324\text{cm}^2$

40. $(420 + 227 + 364) \div 3 = 337$) (Brenda gives $420 - 337 = \$83$) (Dennis gives $364 - 337 = \$27$)